

NORBIT - iWBMS TURNKEY MULTIBEAM SONAR SYSTEM

For High Resolution Bathymetry

Compact and high-resolution curved array bathymetric mapping system by NORBIT.

This all-in-one tightly integrated broadband multibeam turnkey solution offers high resolution bathymetry over a wide swath. The high-end sonar with Applanix WaveMaster II (globally leading GNSS/INS system) embedded into the unit ensures fast and reliable mobilisation and highest quality sounding for surveys in all conditions.

The WBMS-series are based on a flexible sonar platform that utilizes the latest in analogue and digital signal processing. With broad R&D expertise, NORBIT has developed, from the ground-up, exciting new technology that allows existing and new applications to benefit from the advantages offered by a compact wideband curved-array multibeam sonar.

Supported by DCT (NORBIT Integrated Data Acquisition Software) for efficient survey data acquisition.



Features

- ✓ Multibeam Sonar with Integrated Inertial Navigation System & Integrated NTRIP Client
- ✓ 80kHz Bandwidth
- ✓ Roll-stabilisation
- ✓ Backscatter outputs (Intensity, Sidescan, Sidescan Snippets, Snippets, Water Column)
- ✓ Multidetect
- ✓ Simple Ethernet Interface
- ✓ Integrated Sound Velocity Probe
- ✓ Hydrodynamic Fairing
- ✓ Mounting Bracket Included
- ✓ FM & CW Processing
- ✓ Flexible Power
- ✓ Exceeds IHO *Special Order*, CHS *Exclusive Order* & USACE *New Work*

Applications

- ✓ Shallow Water Bathymetry
- ✓ Pipeline Surveys
- ✓ Pond, River and Estuary Surveys
- ✓ Harbor and Lake Surveys
- ✓ Unmanned Surface Applications (AUV or ASV)
- ✓ Coastal Surveys

Options

- ✓ Sound Velocity Profiler
- ✓ Data Acquisition Software (DCT)
- ✓ Turnkey Survey Solutions
- ✓ Permanent Hull Mount Option
- ✓ Pole Mount and Travel Option
- ✓ 200kHz Version
- ✓ Backscattering Strength Output
- ✓ Narrow Beam Option
- ✓ High-end INS
- ✓ Acquisition, Navigation and Post Processing Software
- ✓ 1024 HDS
- ✓ Can be Delivered with Software Packages e.g. DCT, HYPACK, Qinsy, EIVA, CARIS and Others

NORBIT iWBMS Wideband Multibeam Sonar For High Resolution Bathymetry

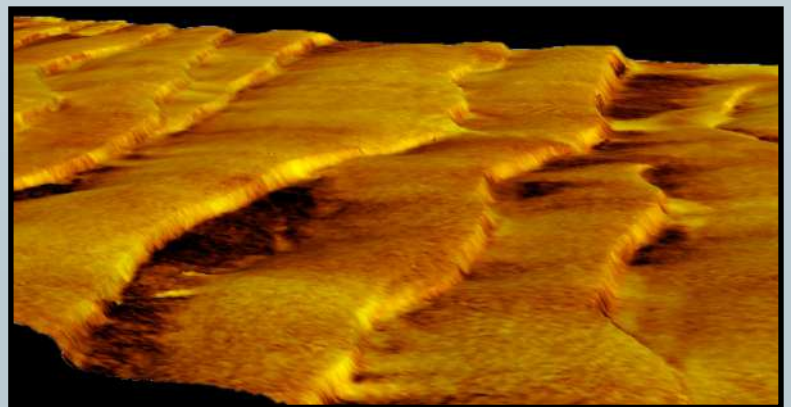
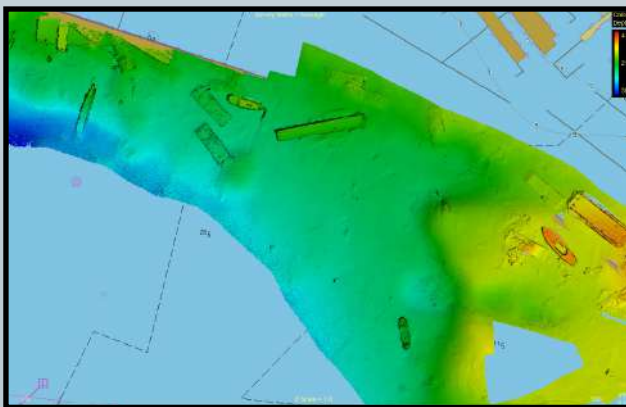
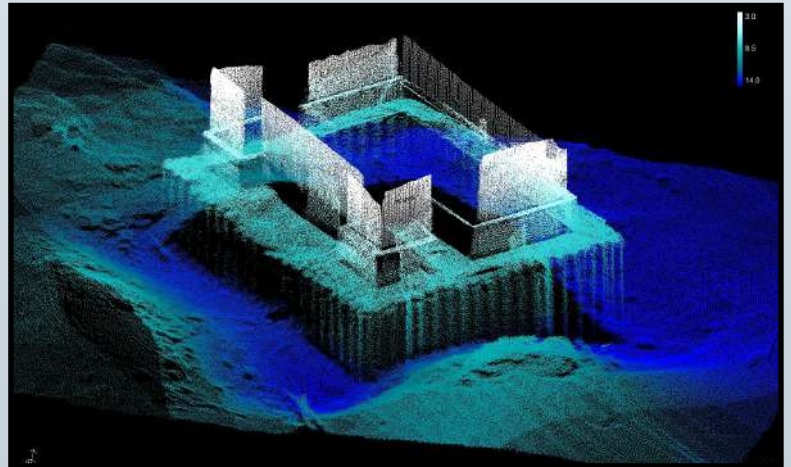
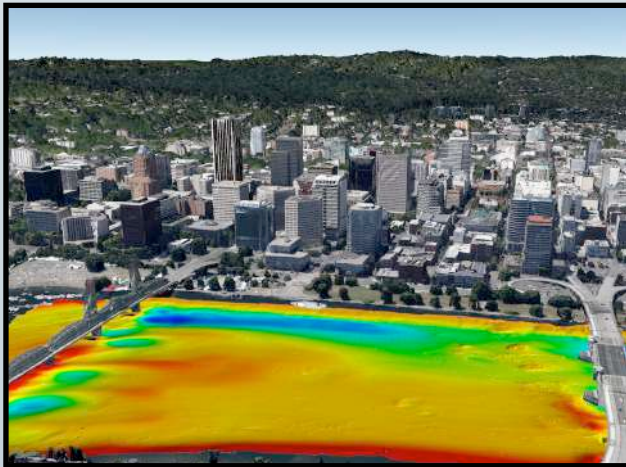

TECHNICAL SPECIFICATION

SWATH COVERAGE	5-210° FLEXIBLE SECTOR (SHALLOW WATER IHO SPECIAL ORDER >155°)
RANGE RESOLUTION	<10mm ACOUSTIC w. 80kHz BANDWIDTH
NUMBER OF BEAMS	256-512 (1024 HDS) EA & ED
OPERATING FREQUENCY	NOMINAL FREQUENCY 400kHz (FREQUENCY AGILITY 200-700kHz)
DEPTH RANGE	0.2-275m (>300m WITH 0.9° X 0.9° OPTION)
PING RATE	UP TO 60Hz, ADAPTIVE
RESOLUTION (ACROSS X ALONG)	STANDARD: 0.9° X 1.9° @400kHz AND 0.5° X 1.0° @700kHz. NARROW OPTION: 0.9° X 0.9° @400kHz AND 0.5° X 0.5° @700kHz
POSITION	HOR: ±(8mm +1ppm X DISTANCE FROM RTK STATION) VER: ±(15mm +1ppm X DISTANCE FROM RTK STATION) (ASSUMES 1m GNSS SEPARATION)
HEADING ACCURACY	0.03° (RTK) WITH 2m ANTENNA SEPARATION
PITCH/ROLL ACCURACY	0.02° INDEPENDENT OF ANTENNA SEPARATION
HEAVE ACCURACY	2 cm OR 2% (TRUEHEAVE™), 5 cm OR 5% (REAL TIME)
WEIGHT	8.5kg (AIR) 3.5kg (WATER)
INTERFACE	ETHERNET
CABLE LENGTH	STD 8m, OPT: 2m, 25m AND 50m
POWER CONSUMPTION	60W (10-28VDC, 110-240VAC)
OPERATING TEMP.	-4°C to +40°C (TOPSIDE -20°C to +55°C)
STORAGE TEMP.	-20°C to +60°C
ENVIRONMENTAL	TOPSIDE: IP67: DUST TIGHT, PROTECTED AGAINST THE EFFECT OF IMMERSION UP TO 1m/WET-END (SONAR): 100m

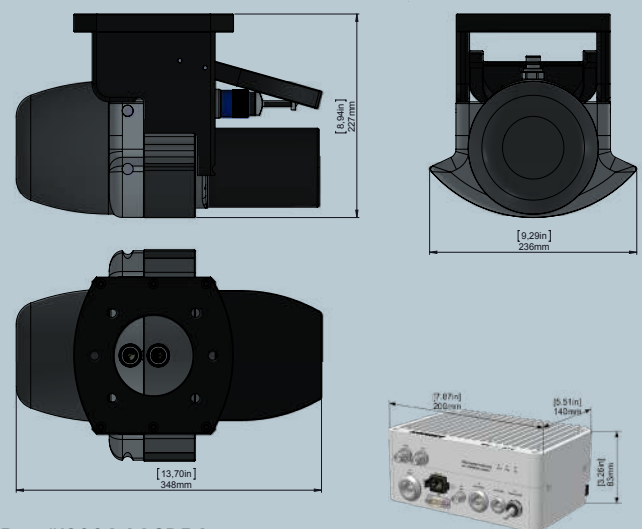

Part #12004-AACDB4